

**WORKING PRINCIPLE OF MANUFACTURING THE SX TYPE COTTON  
SEPARATOR**

**Anafiyeva Shalola Ubaydullo kizi ,**

assistant

Andijan State Technical Institute, Andijan city

**Annotatsiya:** Ushbu maqolamizda paxta tozalash korxonasining texnologik jarayonida qo'llanilayotgan separatorda paxta xom ashyosini havodan ajratib olish vaqtida chigit va tola shikastlanadi. Ushbu taklif etilayotgan separatorda yuqoridagi kamchiliklar bartaraf etilib, paxta xom ashyosining ta'biy xususiyatlari saqlanib qoladi. Natijada paxta tolasining sifati yaxshilanib, korxonaning iqtisodiy samaradorligi ortadi.

**Kalit so'zlar:** Chigitli paxta, seperator, kamera, vakum-klapan, element, ventilator, elektromotor, reduktor, ayланuvchi shnek.

**Аннотация:** В данной статье в сепараторе, используемом в технологическом процессе хлопкоочистительного предприятия, при извлечении хлопка-сырца из воздуха повреждаются семена хлопчатника и волокна. В этом предложенном сепараторе будут устранены вышеперечисленные недостатки и сохранены особенности хлопка-сырца. В результате улучшится качество хлопкового волокна, повысится экономическая эффективность предприятия.

**Ключевые слова:** Хлопок семенной, сепаратор, камера, вакуум-клапан, элемент, вентилятор, электромотор, редуктор, вращающийся шнек.

**Abstract :** In this article, in the separator used in the cotton gin process, when raw cotton is extracted from the air, cotton seeds and fibers are damaged. This proposed separator will eliminate the above disadvantages and preserve the characteristics of raw cotton. As a result, the quality of cotton fiber will improve, the economic efficiency of the enterprise will increase.

**Keywords :** Seed cotton, separator, chamber, vacuum valve, element, fan, electric motor, reduction gear, rotating auger.

Designed to separate cotton from the carrier air flow in pneumatic conveying systems at cotton ginning plants and preparation points.

The air flow with cotton transported through the air duct falls into the inertial separator 4, where it is separated into 2 streams. The lower stream, which has the main weight of cotton, is directed to the separation shaft 2, and the upper stream is directed to the separation chamber 1. In the chamber and shaft, the air loses speed and the cotton falls into the vacuum valve 3. From there, it passes to the next stage of processing.

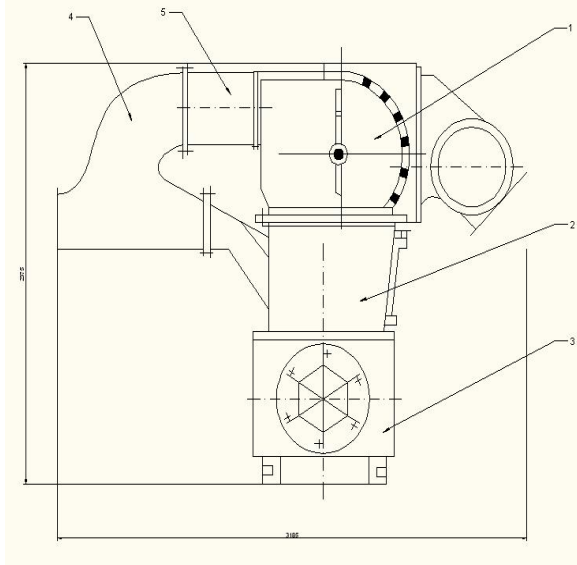

**Figure 2. SX type cotton separator**

1- separation chamber 2–separation shaft 3–vacuum valve 4–inertial separator 5– passage .

Air is sucked in by a ventilator through the mesh and the outlet pipe, and the blades clean the mesh of any fibrous particles and impurities that have fallen into it with the air flow and throw them into the vacuum valve.

Technical characteristics of the SX cotton separator

1.	cotton productivity, t/h .....	22
2.	material loss, % not more	
I, II	.....	0.0024
III, IV	.....	0.013
3.	air flow rate $Q=6 \text{ m}^3/\text{min}$ , m.	
	water column, not much .....	50.0
4.	Mechanical damage to cotton seeds, %	
	not much .....	0.11
5.	installed power, kW .....	9.7
6.	Rotational speeds, rpm:	
	for vacuum valve .....	75
	for propeller shaft .....	75
7.	Overall dimensions, mm, not more than:	
	length .....	3185
	with width divider and conveyor .....	3145
	without width divider and conductor .....	2240
	height .....	2375
8.	weight, kg, not more than .....	1700

List of assembly parts and details for the kinematic drawing of the working bodies of the SX cotton separator

Name	Character	Number per machine
Electric motor, n=1469 rpm, P=7.5 kW	4A132443	1
Coupling 250-25-1.1-381.1	Ye4093.170A	1
Reducer	S2U-160-20-12- VI	1
Clutch	Yen093.740A	1
Bearing	112144	4
Gear motor, n=105 rpm, P=2.2 kW	MSZS-80-71-SUZ	1

Since the SX separator operates primarily on the basis of an aerodynamic process, it is prone to malfunctions due to clogged mesh holes.

The cotton separator is installed in the technological process of cotton ginning plants and separates the raw material from the air. When the separator is operating, air is separated from the cotton along with small impurities using various surfaces installed on the sides of the working chamber.

In the proposed separator, the main part of the cotton entering the working chamber falls into the vacuum valve slots under the influence of its own weight. The cotton falls into the vacuum valve in different thicknesses, and the rotating screw introduced by us spreads the cotton across the width of the separator and adjusts the thickness of the cotton.

In the separator used in the technological process of a cotton ginning enterprise, during the separation of cotton raw materials from the air, the seeds and fibers are damaged. This proposed separator eliminates the above shortcomings and preserves the natural properties of cotton raw materials. As a result, the quality of cotton fiber improves and the economic efficiency of the enterprise increases.

In terms of economic efficiency, seed damage is reduced by 0.83%, the release of free fibers into the air is reduced by 0.53 kg/h, and the amount of defects and impurities in the fiber is reduced by 0.14%.

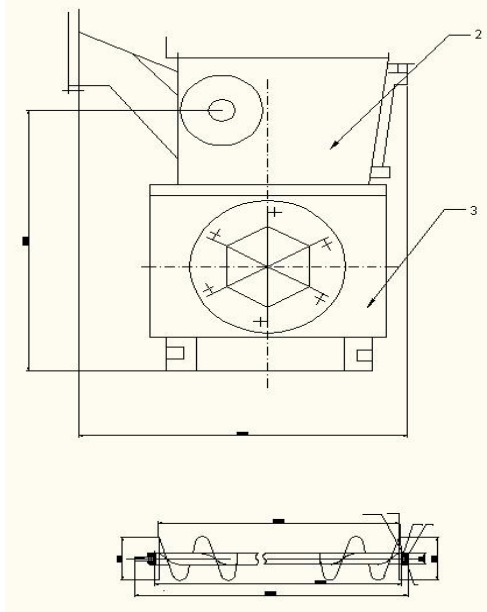

**Figure 2. Improved CX separator assembly**

of pneumatic transport consists of selecting the air speed for transporting cotton, determining the air consumption, and calculating the pressure loss in the pneumatic system. Based on the above parameters, the ventilator is selected and its operating mode and the power of the electric motor driving the ventilator are determined.

For good transportation of cotton seeds in horizontal and vertical sections of the pipes, the air velocity must ensure that the cotton is in a suspended state. In order for the cotton to be suspended in the air flow inside the pipe, the pressure of this air flow on the cotton must be equal to the weight of the cotton. Based on this condition, the suspended velocity is calculated according to the following formula:

$$\vartheta_s = 3,62 \sqrt{\frac{\rho_m}{\rho} * d_m},$$

bu yerda:

$\rho_m$  -density of cotton seed in the tube,  $\text{kg/m}^3$  ;

$\rho$ - air density,  $\text{kg/m}^3$  ;

$d_m$ - diameter of cotton pieces, m.

the diameter of the cotton balls  $d_m$ , the greater their flight speed. The density of air at normal atmospheric pressure  $\rho_m$  is  $1.2 \text{ kg/m}^3$ .

The air speed (m/s) at which cotton can become clogged in the pipe  $\vartheta_s$  depends on the performance of the pneumatic system :  $G_m$

$$\vartheta_s = 5 * G_m^{0.4}$$

bu yerda:  $G_m$  – pneumatic system output on cotton seeds , t/h

$\vartheta_{g_{prom}}$  , should be 1.7 times higher than the air velocity at which cotton can clog , i.e.  $\vartheta_3$

$$\vartheta_g = 1,7 \quad \vartheta_s = 8,5 * G_m^{0.4}$$

B unda trubaning gorizontall uchastkasidagi seed cotton speed (m/s):

$$\vartheta_m = \psi * \vartheta_g$$

Here  $\psi$  is the coefficient indicating the degree of fluffiness of the cotton seed being fed into the pipe. Depending on the efficiency of the equipment

$\psi = 0,5 - 0,75$  will be:

$$G_m = 10 - 12 \frac{t}{soat} \text{ bo'lganda } \psi = 0,5; \vartheta_s = 12,5 \text{ m/s}$$

$$G_m < 10 \frac{t}{soat} \text{ bo'lganda } \psi = 0,5; \vartheta_s = 9,5 \text{ m/s}$$

To avoid loss of speed, the air velocity must be the same in the horizontal and vertical sections of the system. In this case, the air velocity in the vertical section of the pipe  $\vartheta_v = \vartheta_m + \vartheta_s$  must be

of the mass of cotton seed passing through the pipe per unit of time to  $G_m$  the air consumption during this time  $G$  is called the weight concentration of the mixture and is expressed as follows:

$$\mu = \frac{G_m}{G} \text{ here } G = Q * \rho, \text{ kg/s}$$

the weight concentration of the mixture  $\mu$  and the air velocity:

$$Q = \frac{\pi * d^2}{4} * \vartheta \quad d = \sqrt{\frac{4Q}{\pi \vartheta}} = 1,13 \sqrt{\frac{G_m}{\vartheta \rho \mu}}$$

shunga ko'ra  $\mu$  The higher the value, the smaller the pipe diameter. However, if it is too small, the pressure loss will increase.

Paxta tozalash sanoatida diametri When using 400-450 mm pipes and a production capacity of 10-12 t/h, the weight concentration of the mixture  $\mu$  will be = 0.6 – 0.8.

### Conclusion

In the processing of cotton seed, the SX type separator is involved in the process of transporting raw materials to technological equipment. The separator serves to separate the cotton from the air entering the technological equipment in the drying-cleaning and cleaning shops on the technological line. The separator also separates dust and small impurities mainly contained in cotton seed. Its cleaning efficiency is 5-10%.

The separator separates the cotton from the air and evaluates the condition of the remaining equipment after it, depending on its operation at a certain rate. So, the more efficiently the

separator works, the better it will be for processing cotton with seeds. One of the main indicators of the separator is its productivity, cleaning efficiency, and the speed of rotation of the rotating elements and their proper operation.

The cleaning efficiency of a machine depends on the condition of its mesh surface. In order to have good cleaning efficiency, it must have a large usable working surface.

#### **References.**

1. E. Zikryaev, Paxtani dastlabki qayta ishlash, T. "Mexnat" – 2002y
2. A. A. Qodirov «Paxta va to'qimachilik sanoatida TTB» T 2006 yil
3. Г. И. Мирошниченко. Основы проектирования машин первичной обработки хлопка. Москва Машиностроение, 1972 г
4. Болтабоев С. Д., Парпиев А. П. Сушка хлопка-сырца. Ташкент "Ўқитувчи" 1980 г.
5. Г. И. Мирошниченко. и др. Оборудование и технология производства первичной обработки хлопка, Ташкент, "Ўқитувчи" 1980 г
6. G' . J. Jabborov, T. U. Atametov Chigitli paxtani ishlash texnologiyasi, Toshkent, "O'qituvchi" 1987 y.